

**Item Description**

**Mounting Type-** Recessed / Suspended / Wall mounted  
**Housing-** PMMA LGP  
**Diffuser-** PMMA  
**Life Span-** > 50,000 Hrs (Ta = 30°C LM70)  
**Option-** Non Dimmable / Dimmable DALI / 0~ 10V/ Triac  
**Standards-** EN60598-1 / EN60595-2-1



High CRI



Energy Saving



Long Lifespan



Uniformed Lighting

**Features**

**Internal Details**

1. Quality LED
2. LED Protector
3. UV solidity technology
4. Tracking code

**External Details**

1. Elegant appearance
2. No light leakage
3. Wire clamp
4. Embedded nuts groove

**Usage**

Can be used in office, Industry, classroom and stores.

CODE	WATTAGE	LUMENS	KELVINS	DIMENSIONS
PANEL 65	40W	90lm/W	4000K	595*595mm

**Accessories**

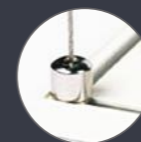

Steel Cable

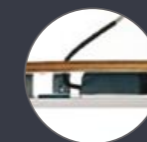

L-shaped Brackets

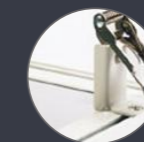

Spring Kits

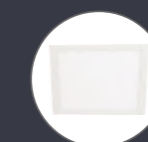

Z-shaped Bracket

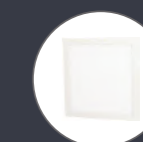

Wall Mounted Kits

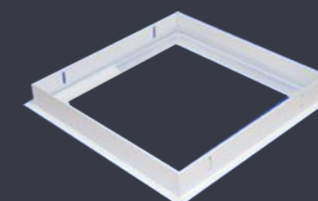

Gypsum Board Frame

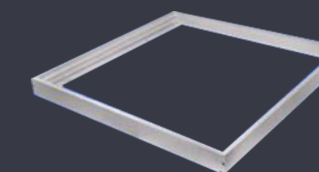

Push-in Surface Mounted Frame

**Structure**

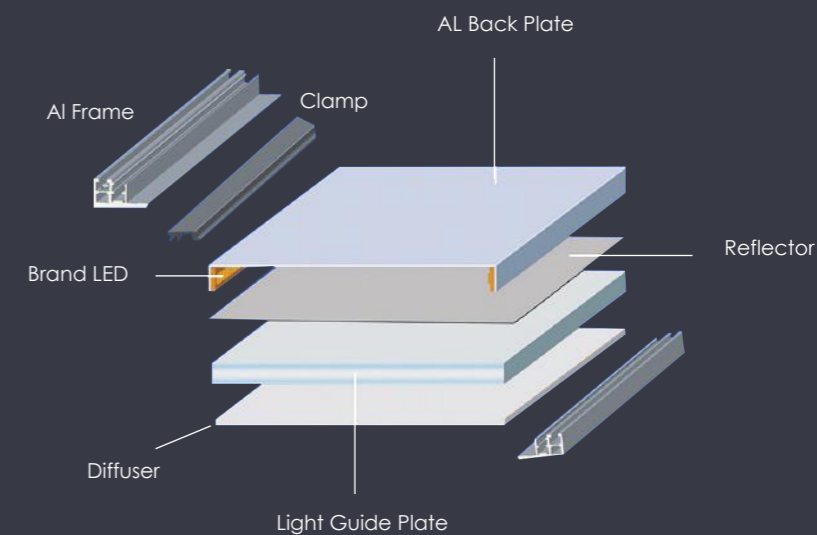

**Waterproof Tech**

**Silent Protection inside**

- Invisible silicon gasket
- Protecting edges against splash
- Water resistant
- Dust resistant
- Humidity Resistant

