

Item Description

Mounting Type- Ceiling Recessed

Housing- Die-Cast Aluminum

Diffuser- PMMA

Reflector- White

Life Span- > 50,000 Hrs (Ta = 30°C LM70)

Option- Non Dimmable / Dimmable DALI / 0~ 10V/ Triac

Standards- EN60598-1 / EN60595-2-1

Objective

Using our latest technology to make a combination between decoration & efficiency.

PENOVA SQUARE-09-15-20 is square, slim trim and deep frame with total high <25mm. Aluminum PCB equipped with SMD light source center emitting.

It can be used in Retails, Residentials and Hotels.

CODE	WATTAGE	LUMENS	CRI	KELVINS	DIMENSIONS
PENOVA SQUARE-09	9W	800lm	>80	2700-3200K/3800-4200K/5700-6000K	101x101x160mm
PENOVA SQUARE-15	15W	1370lm	>80	2700-3200K/3800-4200K/5700-6000K	135x135x200mm
PENOVA SQUARE-20	20W	1800lm	>80	2700-3200K/3800-4200K/5700-6000K	158x158x225mm

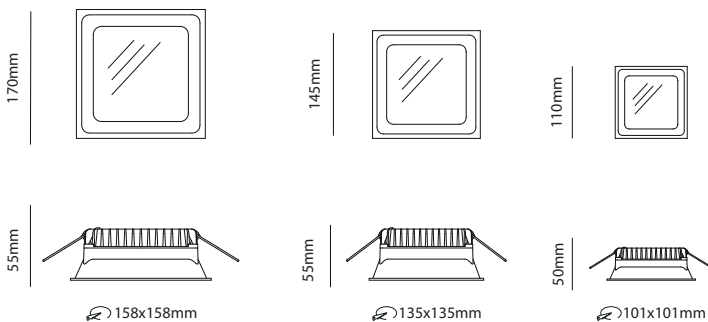

Colours



01. White 02. Black 03. Silver 04. Grey