



Item Description

Mounting Type- Surface / Suspended

Housing- Die-cast Aluminum

Diffuser- PC (On demand)

Life Span- 50,000 Hrs

Heatsink temperature- 5~+55°

Ambient temperature- -30~+75°

Beam Angles- 110°

Option- Non Dimmable / 1-10V or DALI dimmable driver available

Standards- EN60598-1 / EN60595-2-1 / CE

Designed for industrial lighting adopting the newest LED lighting technology with 180 lm/w light efficiency. High grade materials and perfect workmanship provide excellent cooling abilities and a long lifespan with 5 year warranty.

It is made specially for Industrial use, Warehouses & Factories, Industrial Locations, Bunkers & Factories.

CODE	WATTAGE	LUMENS	CRI	KELVINS	DIMENSIONS
FLY-100	100W	16500±1000	>80	3000K/4000K/5000K/6000K	Φ280*188mm
FLY-150	150W	24750±1500	>80	3000K/4000K/5000K/6000K	Φ280*188mm
FLY-200	200W	33000±2000	>80	3000K/4000K/5000K/6000K	Φ320*188mm

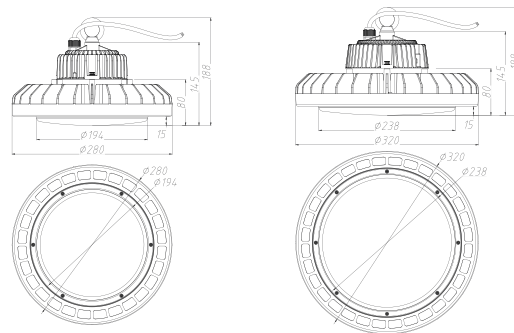

Exploded drawing

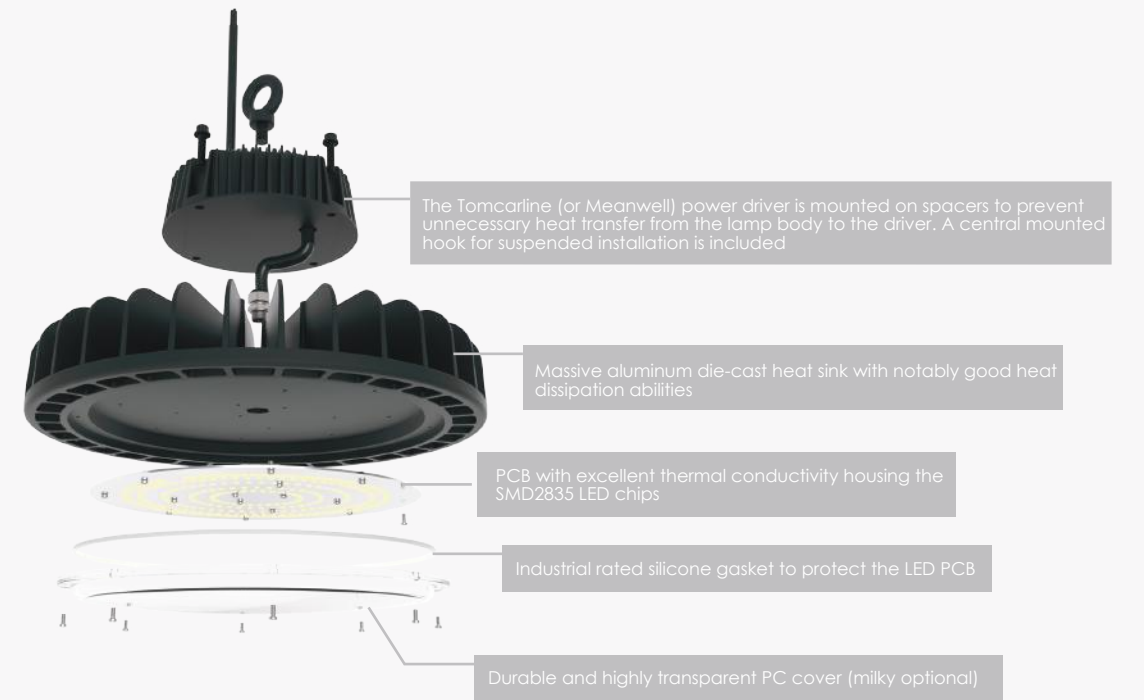

Optional accessories



Dimmable driver 1-10V



DALI dimmable driver



IP65 microwave motion sensor (Merrytec model:MC031V-C)



Surface mounting/wall mounting bracket



Safety rope(0.5m length)



Zigbee control



Frosted PC cover

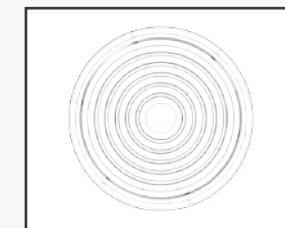

60°/ 90° lens